

V-PRO

Portable VOCs Gas Detector with Pump

USER MANUAL



SENKO

www.senkoeu.com

PRODUCT OVERVIEW

V-PRO is a portable VOC gas detector with a built-in pump which warns of a dangerous gas environment. The detector indicates the concentration of VOC gas on the LCD display. It is easy and simple to operate. The device alerts the operators of danger with an audible, visible, and vibration alarm when the concentration exceeds safe gas levels. The device shows the gas concentration in real time and identifies the maximum and minimum concentrations. The settings can be adjusted through Wireless or the SENKO IR-LINK (option).



Warning

- Please do not replace or change any parts. Unauthorized replacement of parts may invalidate the warranty and compromise safety.
- Please remove any debris on the surfaces of the sensor, LED or buzzer / pump hole before use.
- Test the performance of the gas sensor using bump test and calibration gas regularly. The gas should trigger an alarm to be successful.
- Test whether the LED, alarm and vibration function properly on a regular basis.
- Using the device in conditions outside the certified temperature, humidity and pressure range may cause the instrument to malfunction or fail.
- The sensors inside the device may indicate the gas concentration differently according to the temperature, pressure and humidity they are in. Please make sure to calibrate the detector in the same environment in which it will be used.
- Extreme changes in temperature may cause drastic changes of the gas concentration. (e.g. using the detector where there is a huge gap between the inside and outside temperature) Please use the device when the concentration becomes stable.
- Severe pressure or impact may cause drastic changes of the gas concentration. Therefore, please use the device when the concentration is stable. Severe pressure or impact may cause also malfunction in the sensor or the device.
- The alarms are set according to the international standard and must be changed by an authorized expert.
- Charging or replacing the battery must be done in a safe area where there is no risk of explosion or fire. The use of spare parts not supplied by the manufacturer will invalidate the warranty.
- IR communication should only be done in a safe area where there is no risk of explosion or fire.
- Do not expose the detector to poisons such as alcohol and citrus based products, as poisons may damage the device's accuracy and response time.
- If you suspect sensor poisoning, bump test and calibrate the instrument before further use.
- The detector is designed for use only in potentially explosive atmospheres where oxygen

concentrations do not exceed 20.9% (v/v). Oxygen deficient atmospheres (<10% v/v) may suppress some sensor outputs.

- Recharge the battery before it is discharged.
- Charge the detector in temperature ranged from 0°C to 40°C
- The efficiency of the rechargeable battery decreases by approximately 20% after two years of normal use.
- Do not use any other charging adapter.
- Do not calibrate the device while or immediately after charging the battery.
- Do not calibrate if exposed to the condition representative of the IP rating.
- Do not perform the calibration during the stabilization process after turning on the device.
- Sudden changes in atmospheric pressure may temporarily destabilize oxygen concentrations.
- Before daily use, check the pump port is clear of any obstructions, debris, or blockage.
- If the pump port is blocked by any pollutants, the measured reading may be lower than the actual concentration.
- The equipment must be always carried and should not be left unattended.
- If there is a charging mechanism, the exposed metal parts of the enclosure may store electrostatic charges that could pose an ignition risk to IIC gases. Therefore, users must implement measures, as listed above, to prevent the accumulation of electrostatic charges. This is especially important when the equipment is brought into a Zone 0 location.
- The equipment must only be charged in non-hazardous areas and must be used with a charger specifically provided for use with units approved as SELV or Class 2 equipment in accordance with IEC 60950, IEC 61010-1, or equivalent IEC standards (e.g., part number ICP12-060-1200D manufactured by ShenZhen Shi Ying Yuan Electronics Co, LTD). The maximum voltage and current of the charger must not exceed 6.2 Vdc and 1.2 A, including tolerances, and should be further limited to $U_m = 6.2$ Vdc. The ambient temperature during charging must be between 0°C and 45°C.
- The battery and sensors should only be replaced by SENKO authorized service providers in a safe zone, free of hazardous gases.



Caution

- Please use after reading the manual carefully
- This device is not a measurement device, but a gas detector.
- Please stop using and consult the manufacturer if the calibration fails continuously.
- Please test the device every 30 days under the atmospheric environment of clean air without gases.
- Clean the exterior of the device with soft cloth and do not clean it with chemical detergents.

CONTENTS

1. Production Overview.....	5
1.1. Introduction	5
1.2. Specification.....	5
1.3. External Components	6
1.4. LCD Display Symbols.....	6
2. Basic Operation.....	7
2.1. System Activation.....	7
2.2. System Shutdown.....	8
3. User Mode	8
3.1. User Mode Operation Sequence.....	8
3.1.1. Button	8
3.2. Pump Status.....	9
3.2.1. Pump Blockage Level Setting	9
3.2.2. Pump Speed Setting	9
3.3. Bump Test	9
3.4. Calibration	10
3.4.1. Calibration Type.....	10
3.4.2. Other Settings	10
3.5. Measurement	11
3.5.1. Unit of Measurement	11
3.5.2. Measuring gas	11
3.6. Alarm	11
3.6.1. Alarm Menu.....	12
3.7. Data Log	13
3.8. Wireless Interface	13
4. Display.....	13
4.1. Measurement Mode	13
4.2. Configuration Mode	13
4.2.1. Calibration Settings	14
4.2.2. Measurement Settings	15
4.2.3. Alarm Settings	15
4.2.4. Data Log Settings.....	16
4.2.5. Monitor Settings.....	16
4.2.6. Wireless Connection.....	17
4.3. Battery.....	17
5. Data Log.....	18
6. Failure / Escape	18
7. Certification	19
8. Trouble Shooting	19

1. Production Overview

1.1. Introduction

V-PRO is a portable VOC gas detector designed to ensure the safety of workers in hazardous environments where various gases are present.

This detector measures VOC gases in real-time through its built-in pump and displays the gas concentration on an LCD monitor. With its user-friendly and intuitive interface, the V-PRO immediately alerts users to danger through an audible alarm, LED indicators, and vibration when gas concentrations exceed safety thresholds.

Additionally, it allows for identification of maximum and minimum concentrations, and settings can be easily adjusted via Bluetooth or Senko IR-LINK(Optional).



1.2. Specification

Model	V-PRO
Measuring Gas	VOCs
Measuring Mechanism	Photo-ionization
Measuring Type	Sampling Type
Dimension	77(W) x 146(H) x 54(D)mm
Weight	370g
Case	Rubber -Type Polycarbonate
Battery	3.7VDC Lithium-ion Battery (Voltage: 3.7V, Capacity: 4,400mAh)
Operating Time	> 30 hours
Operating Temperature	-20°C to +50°C
Humidity	10 to 90% RH (Non-condensing)
Alarm	Visual (LED), Tactile (Vibration), Audible (95dB) alarms Primary and Secondary Alarm Configurable
Interface	LCD Display, Alarm LED, Buzzer, Button, Gas Inlet
Display	Gas Type, Alarm Level (ppm or %Vol concentration), Alarm Setpoints (primary & Secondary), Maximum/Minimum Concentration Display
IP	IP 67
Environmental Conditions	Pollution Degree: "2", Atmospheric Pressure: 80 ~ 120KPa
Components	Charger, Particle Filter, Probe cap
Warranty	2 years (from the date of purchase from the manufacturer or an authorized reseller)
Certification	IECEX Ex ia IIC T4 Ga ATEX II 1 G Ex ia IIC T4 Ga

1.3. External Components



1.4. LCD Display Symbols



	HIGH	High Alarm		Pump status
	LOW	Low Alarm		Bump Test Alarm
		Wireless connection		Standard gas Calibration
	STEL	STEL Alarm		Battery
	TWA	TWA Alarm		Self-Test Success
		Buzzer Set		Data Log Saving

2. Basic Operation

2.1. System Activation

Press and hold the Power/Enter button for 3 seconds to display the SENKO logo and power on the device. Once the device is powered on, version information, Self-Test, and other details will be displayed, followed by the measurement screen (main screen).

If an issue occurs during this process, the device will enter error mode, and an error code will be displayed. For detailed information on the error codes, refer to 'Error Codes' on page 18.

<p style="text-align: center;">SENKO logo</p> 	<p style="text-align: center;">Device Information</p> <p style="text-align: center;"><u>Dev Info</u></p> <p>MODEL: V PRO FW: UPA240625001 SN: 1234567</p>	<p style="text-align: center;">Self-Test</p> <p style="text-align: center;"><u>Date. Info</u></p> <p>Date: 2024/07/10 Time: 15:34:43 Temp: 24.9°C</p>
<p style="text-align: center;">Self-Test</p> <p style="text-align: center;"><u>Self Test</u></p> <p>Pump <input checked="" type="checkbox"/> Clock <input checked="" type="checkbox"/> Datalog <input checked="" type="checkbox"/> PID <input checked="" type="checkbox"/> Wireless</p>	<p style="text-align: center;">Calibration Information</p> <p style="text-align: center;"><u>Cal. Info</u></p> <p>Last Date: 2000/01/01 Cal.Gas: 2000/01/01 Meas.Gas: 2000/01/01 CF: 1.00</p>	<p style="text-align: center;">Battery Information</p> <p style="text-align: center;"><u>Battery Info</u></p> <p>Type: Li-Ion Voltage: 3.98v Shut Off: 3.35v</p>
<p style="text-align: center;">Alarm Information</p> <p style="text-align: center;"><u>Alarm Info</u></p> <p>Mode: Auto Reset Beep: On LED: On</p>	<p style="text-align: center;">Calibration Reference</p> <p style="text-align: center;"><u>Cal. Ref</u></p> <p>HIGH: 100ppm LOW: 50ppm STEL: 35ppm TWA: 10ppm Span: 100ppm</p>	<p style="text-align: center;">Main screen</p> 

2.2. System Shutdown

Press and hold the Power/Enter button for 3 seconds to display the 'sys off' message on the LCD screen, and the 3-2-1 countdown will begin. Once the countdown is complete, the device will automatically power off.

(If the button is not pressed for more than 3 seconds, the device will not power off.)

Warning

The user must ensure that the equipment is accurately detecting the hazardous gas levels. Additionally, the user should check that the gas inlet (pump) is not blocked by any obstructing substances.

3. User Mode

3.1. User Mode Operation Sequence

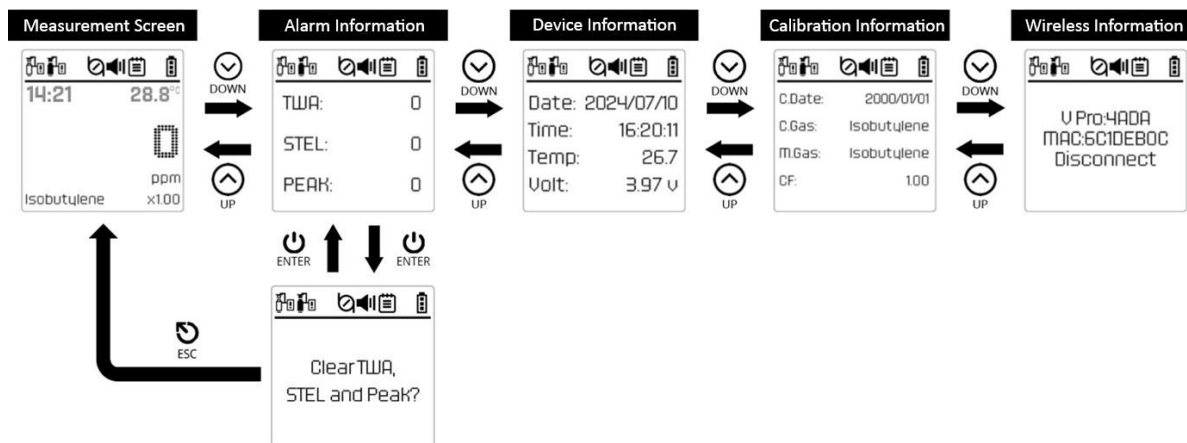



3.1.1. Button

Button	Name	Main Screen Action	Config Screen Action	List Action	Move Action	Value Action
⬆	Up	NEXT	NEXT	UP		UP
⬇	Down	BACK	BACK	DOWN		DOWN
⌫	Esc	ESC	ESC	ESC	RIGHT MOVE	ESC
⏻	Enter	OK	SELECT	OK		OK

- Enter Setup Menu: Press UP + DOWN buttons for 3 seconds.
- If no button input is detected for 1 minute in the setup menu, it will return to the main screen.

3.2. Pump Status

If the gas flow is interrupted, the detector will send an LED and buzzer alarm every second according to the setting option selected. In normal conditions, no alarm will sound. To cancel the alarm, press the ESC button.

-  Pump Normal Operation
-  Pump Blockage Error

3.2.1. Pump Blockage Level Setting

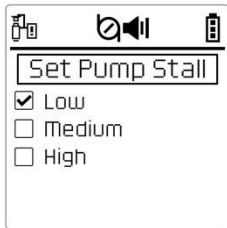

The pump blockage level can be set to High/Medium/Low. The default setting is **Low**.

3.2.2. Pump Speed Setting

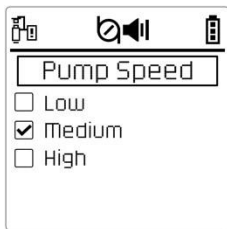

The pump speed can be set to High/Medium/Low. The default setting is **Medium**. The difference in pump intensity between the High and Low settings is approximately 30%.

3.3. Bump Test

A bump test is performed to check the functionality of the sensor and alarm. This test involves exposing the sensor installed in the device to a calibration gas with a concentration slightly above the sensor's low alarm setpoint. (The accuracy of the sensor is not measured during the bump test.)

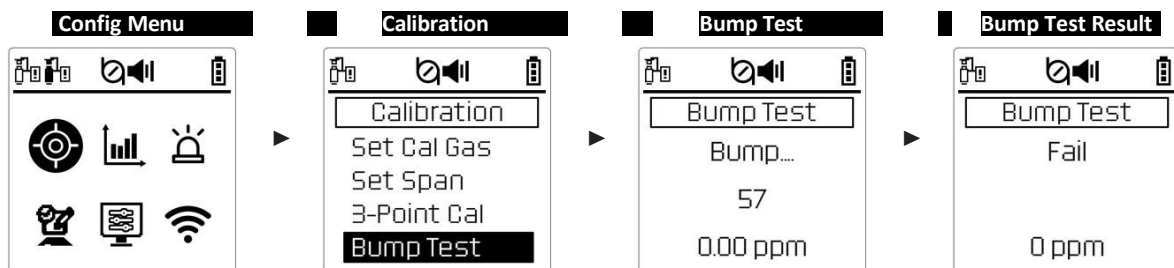

- Menu Path: Config Menu → Calibration → Bump Test
- The Bump Test is performed for 60 seconds. It is considered normal if the reading is equal to or greater than the Low alarm value.
- Result Display: The Bump Test result will be displayed as 'Done' or 'Fail' for 3 seconds.
- Bump Interval Setting: The interval can be set between 1 day and 365 days, and can be configured via IR Link.
- When the set period expires, the Bump icon () will blink at a 1-second interval.

3.4. Calibration

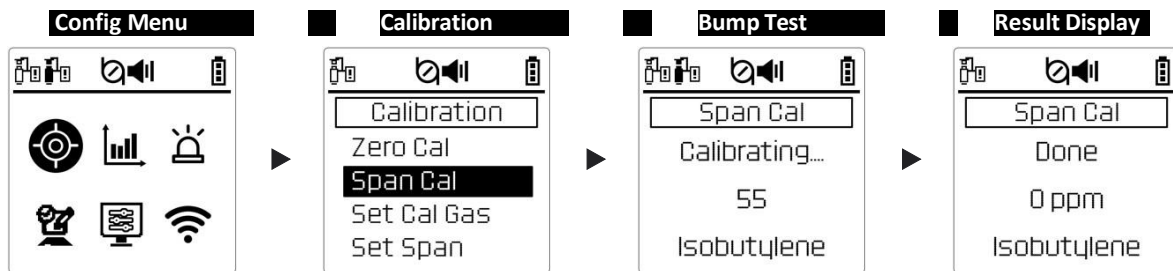

- Menu Path: Config Menu → Calibration → Zero / Span / Span2
- Procedure: Press the Enter button to start calibration, which will take between 10 to 60 seconds.
- Result Display: The calibration result will be displayed as 'Done' or 'Fail'.
- Calibration Interval Setting: The interval can be set between 1 day and 365 days, and can be configured via IR Link.
When the set period expires, the calibration icon will start blinking.
- Both a Zero and Span calibration should be completed every 6 months

3.4.1. Calibration Type

- Zero Cal(Fresh Air Calibration) : Sensor Initial Value Setting with Clean Air
- Span Cal(Standard Gas Calibration) : Standard Gas Calibration
- Span2 Cal(Standard Gas High Concentration Calibration) : High-Concentration Gas Calibration

Warning

- The sensor's sensitivity gradually decreases over time, reducing its ability to accurately measure gas concentrations. However, regular calibration can compensate for the loss of sensitivity.
- If the sensor's sensitivity falls below an acceptable level, the device may no longer be adjustable, and calibration may fail.
- Calibration is recommended if the device has been dropped, subjected to impact, failed the Bump Test, repeatedly exposed to gas concentrations exceeding the specified range, or after replacing the sensor.

3.4.2. Other Settings

- Set Cal Gas: Set the gas value for the gas to be used for calibration.
- Set Span: Set the concentration of the gas to be used for Span calibration. The corresponding ADC value will be adjusted based on the set concentration.
- 3-Point Cal: If using Span2 calibration (high-concentration gas calibration), select "On" from this menu.
Pump Cal - Set the target flow rate: After connecting the Flow Meter to check the flow rate, you can set the target flow rate. After setting the target flow rate using Pump Cal, setting the Pump Speed to Medium will cause the Pump Duty to be automatically adjusted to achieve the target flow rate.

3.5. Measurement

- Menu Path: Config Menu → Measurement → Meas.Unit / Meas.Gas
In this menu, you can set the measurement units and the measured gas.





3.5.1. Unit of Measurement

Unit of Measurement	Description	Comparison
PPM	Represents the number of milligrams In 1 kg of solution	1 ppm is a concentration of 0.000001%
mg/m3	Refers to the concentration In milligrams per cubic meter	Calculated by converting using a volume of 24.1 at 1 atmosphere and molecular weight
umol/mol	Amount of solute dissolved in 1 liter	1ppm =1umol/mol

3.5.2. Measuring gas

- You can select the type of gas to be measured.
- The measurement ratio and molecular weight are adjusted according to the selected gas.
- Based on the selected measurement gas and calibration gas, the concentration and ratio of the measured gas are adjusted and displayed on the screen.

3.6. Alarm

Type	Set-Off Condition	LCD Display	Alarm Sound & Vibration Display
LOW Alarm	Exceed LOW alarm value	Test icon & gas concentration levels displayed	
HIGH Alarm	Exceed HIGH alarm value	Text icon & gas concentration levels displayed	
TWA Alarm	When exceeding TWA alarm value	Text icon & gas concentration levels displayed	
STEL Alarm	When exceeding STEL alarm value	Text icon & gas concentration levels displayed	
Bump Test	Request Date for Bump Test	Bump icon blinking	Stops after Bump Test
Execute Calibration	Request Date for Calibration	Calibration icon Blinking	Stops after Calibration

- **LOW Alarm / HIGH Alarm Sets Off** : When the LOW/High Alarm is triggered, the user must immediately leave the area and move to a safe zone where the gas concentration is normal. The sound alarm, vibration, and LED alarm will stop once the user enters the safe zone.

- **TWA Alarm Sets Off:** If the average gas concentration over the past 8 hours exceeds the TWA concentration, the alarm will sound. Once the user moves to a safe area where the gas concentration level drops below the alarm threshold, the sound alarm, vibration, and LED alarm will stop.
- **STEL Alarm Sets Off:** If the average gas concentration over the past 15 minutes exceeds the STEL concentration, the alarm will sound. Once the user moves to a safe area where the gas concentration level drops below the alarm threshold, the sound alarm, vibration, and LED alarm will stop.

Note

- When a gas alarm occurs, promptly identify the cause of the alarm and evacuate to a safe area to take appropriate action.
- The gas alarms set at the factory during shipment are non-latching. The low alarm, high alarm, and STEL/TWA alarms can also be configured with the latching option via IR-LINK (optional) on a computer.
- The alarm on/off function can also be changed via IR-LINK.

3.6.1. Alarm Menu

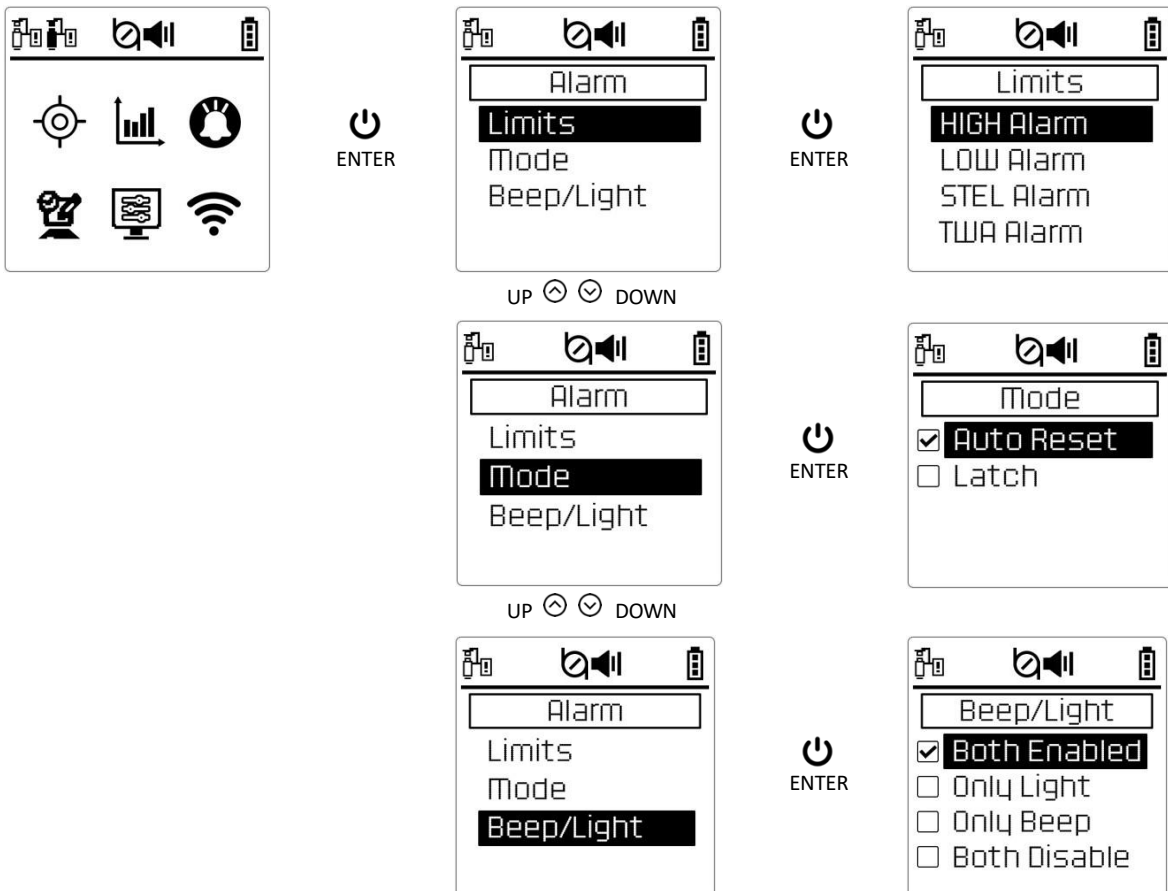

3.7. Data Log

- Menu Path: Config Menu → Datalog → Clear Log / Interval Set
- In this menu, you can clear the data log or adjust the storage interval.
- The data log is set to a **1-minute interval by default**, and the interval can be set from 1 second to 3600 seconds.
- When the data log is being saved, the icon () will blink..

3.8. Wireless Interface

- Menu Path: Config Menu → Wireless → Power Control
- In this menu, you can turn the wireless interface device on and off.
- When the wireless interface is connected, the icon () will appear at the top of the screen.

4. Display

4.1. Measurement Mode

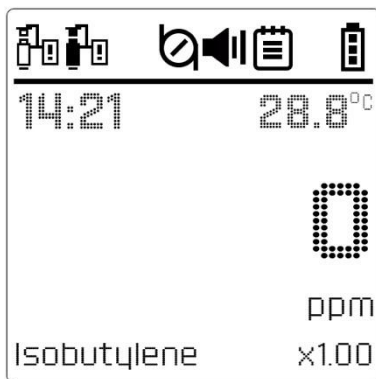

After the device stabilizes and switches to normal measurement mode, the gas concentration and battery power level will be displayed on the LCD screen. The gas concentration is shown in PPM, and the value is updated in real-time as the concentration level changes.

If the concentration exceeds the low alarm (LOW) or high alarm (HIGH) threshold, or if the TWA/STEL limits are exceeded, the corresponding LOW, HIGH, TWA, or STEL icons will blink periodically, and the alarm, LED, and vibration will be activated.

When the device is moved to a safe area, the detected gas concentration will decrease, and the alarm will stop. However, the alarm icons will not disappear. To clear the alarm icons, press the Enter button.

4.2. Configuration Mode



Press both the Up and Down keys simultaneously on the main screen to open the configuration menu on the left. The selected icon will be highlighted with a border. Use the Up or Down keys to navigate to the desired option, then press the Enter key to select it. The settings are available in the following order: Calibration → Measurement → Alarm → Log → Monitor → Wireless Settings.

To exit the configuration mode and return to normal operation, repeatedly press the Esc key from the configuration menu screen.

4.2.1. Calibration Settings

You can set the device's Zero and Span values to accurately measure the concentration of gases based on the sensor.

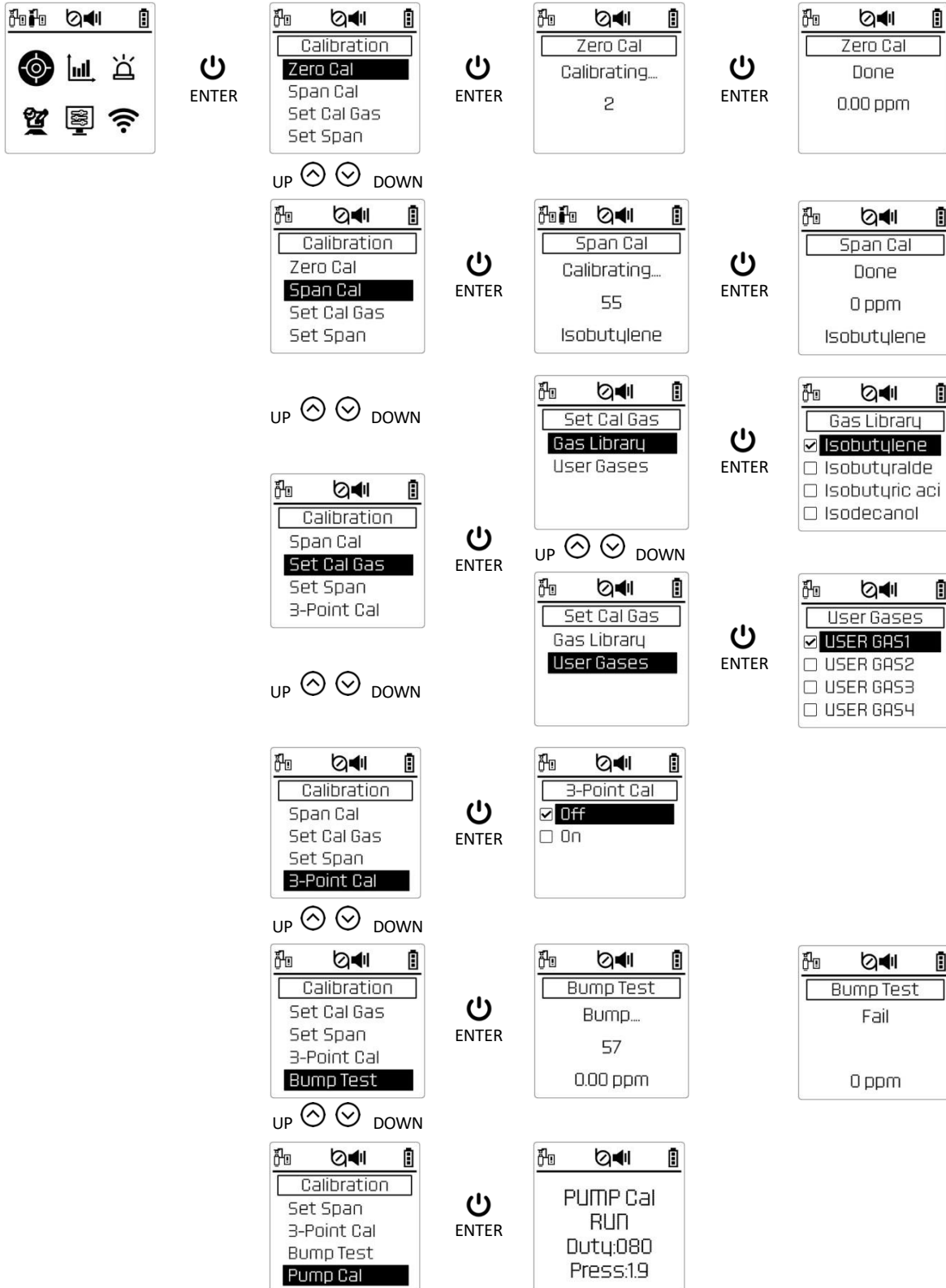

4.2.2. Measurement Settings

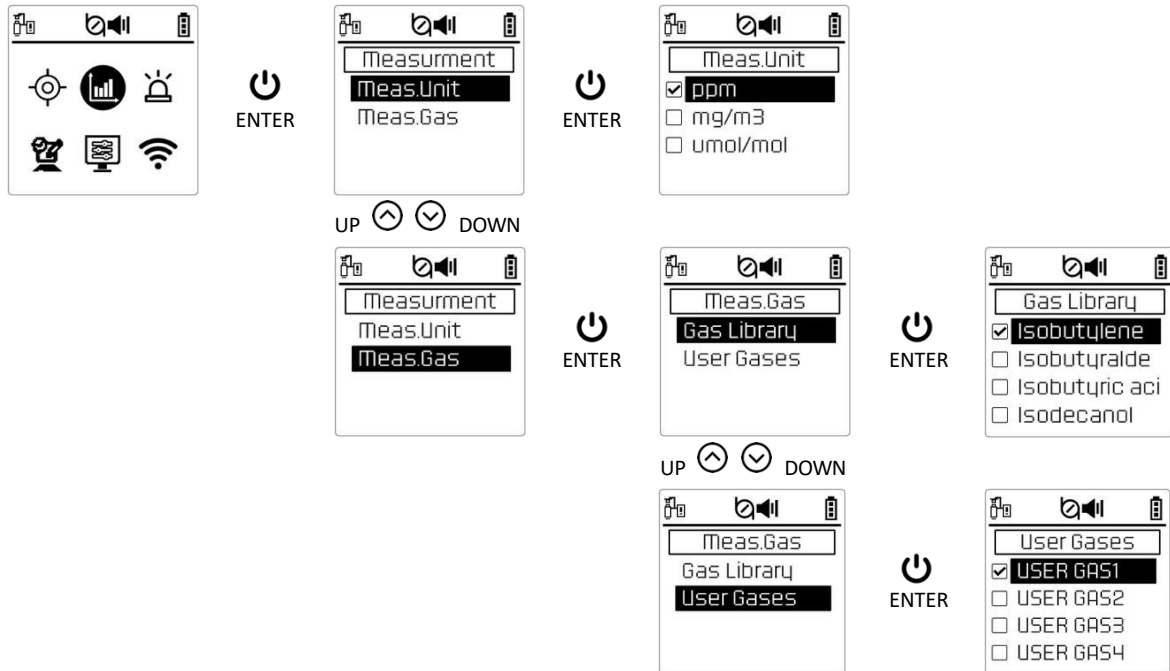

4.2.3. Alarm Settings

You can set the alarm concentration, as well as configure the alarm deactivation, LED, and Buzzer settings.

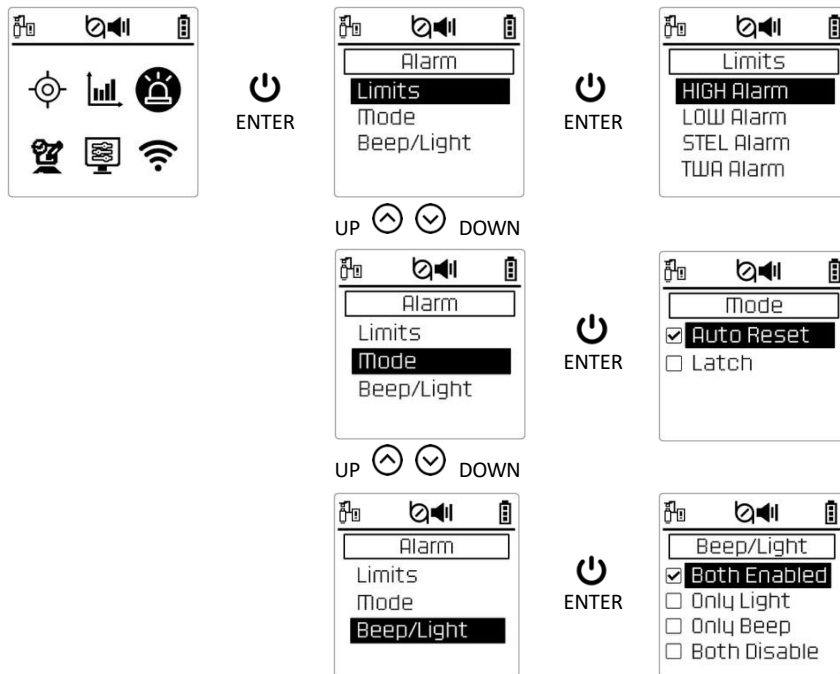

4.2.4. Data Log Settings

In the log menu, you can delete the stored logs or set the log saving interval.

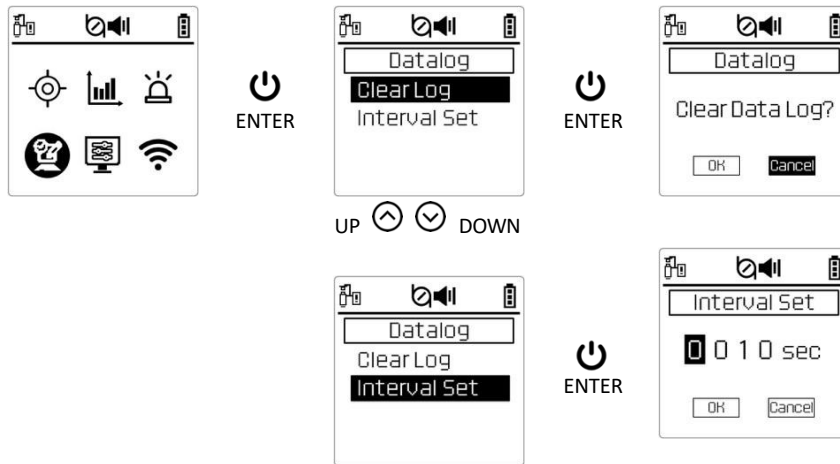

4.2.5. Monitor Settings



Through the menu, you can adjust the date, time, pump speed, and other settings. Date/Time/Display/Pump Speed/Set Pump Stall/Self Zeroing/Temp Unit/Site ID/User ID/Decimal point

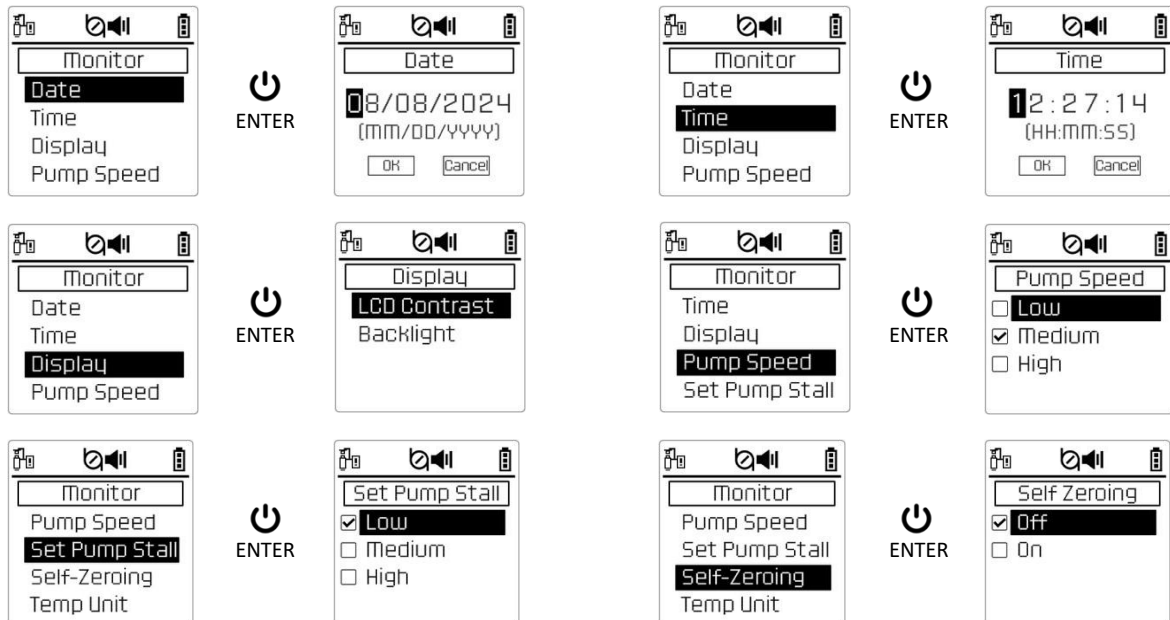

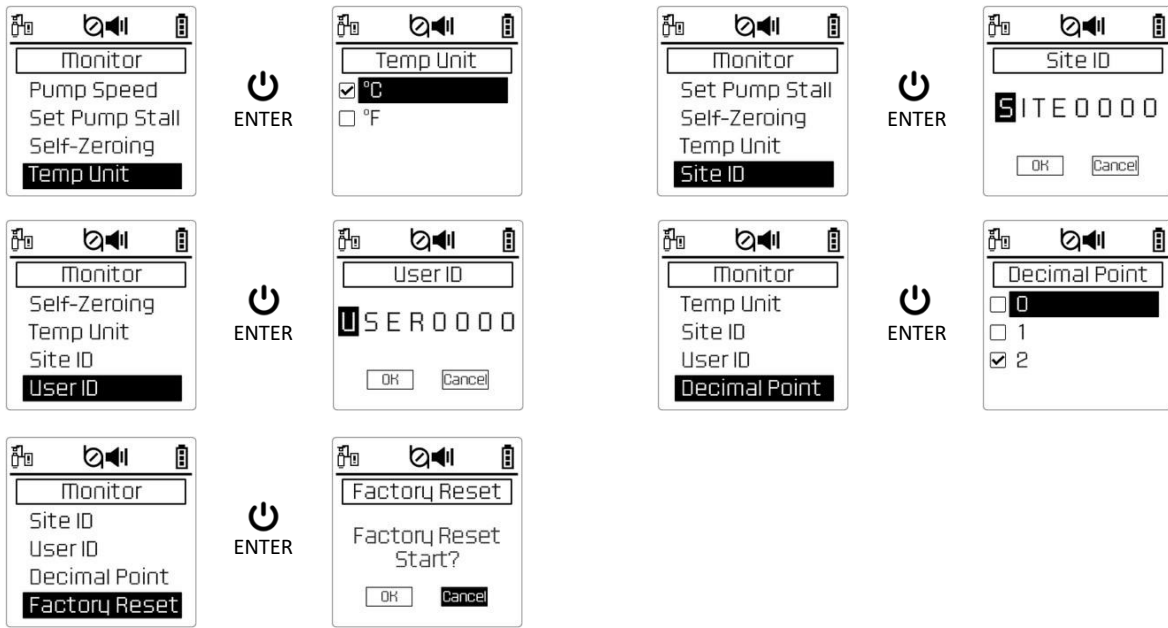

4.2.6. Wireless Connection

You can turn the wireless interface on or off.

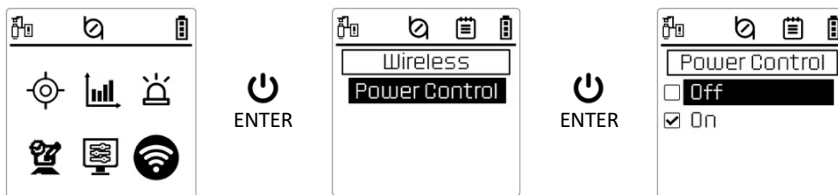

4.3. Battery

The battery is indicated with a 3-level status icon (High, Medium, Low). When the battery reaches the Low level, the device will provide an alarm every 3 minutes. When the battery reaches the End status, the "LOW BATTERY" message will appear on the LCD for 2 seconds before the device powers off.



To charge the device, connect the provided charging adapter to the device, then plug it into an AC outlet. The device will display a rotating icon to indicate that it is charging until the battery is fully charged. Once the charger is removed, the battery icon will show the current battery status.

Warning

- Do not charge the device in explosive environments.
- Do not charge the device if the temperature is outside the specified range (0°C to 40°C).
- Do not replace the battery with any type other than the one specified and provided by the manufacturer.

5. Data Log

The device stores all user activities during operation. The stored data can be downloaded to a PC via the SENKO IR-LINK. A maximum of 30 events, Bump and Calibration logs can be saved, and when the list exceeds 30 entries, the oldest data is automatically deleted.

The data log records operational status at intervals from 1 to 3600 seconds. The general data log stores approximately 2 months' worth of data. (If alarm frequency or setting changes occur continuously, the data log may be stored for less than 2 months.)

Category	Details
Event (High, Low, TWA, STEL) Alarm	Occurrence Time, Duration, Alarm Type, Gas Concentration, Serial Number
Bump Test Log	Test Date, Pass/Fail, Calibration Gas Concentration, Detected Concentration
Calibration Log	Calibration Date, Type, Calibration Gas Concentration, Detected Concentration
Data Log	Time, IR Link Execution Date, Concentration, Alarm Type, Options

6. Failure / Escape

If the device is not operating properly, it will display an error code on the LCD. After noting the code number displayed on the LCD, check the status as described below and take the necessary actions.

Error Code	Description	Necessary Actions
I1	PID Sensor Lamp Error	Lamp Replacement or Cleaning
I2	PID Sensor Oscillator Error	PID Sensor Replacement
I3	PID Sensor Oscillator Overload Error	PID Sensor Replacement
I4	PID Sensor Power Supply Error	Check Device Power Status

The table above shows the error code details. If an error code occurs and the issue is not resolved by turning the power off and on, please contact your local distributor. (For pump operation, the system continuously checks from the moment the power is turned on until it is turned off, and an alarm will sound every second if an issue occurs.)

7. Certification

✓ FCC Class A Device

This device has been tested and found to comply with the limitations of a Class A digital device under FCC Part 15 regulations.

These limitations are intended to provide reasonable protection against harmful interference when the equipment is operated in a commercial environment. This device can generate, use, and radiate radio frequency energy, and if not installed and used in accordance with the instructions, it may cause harmful interference to radio communications.

When operating this device in a residential area, harmful interference may occur. In such cases, the user is responsible for taking appropriate measures to resolve the issue.

	Certifications	Standards
IECEX	IECEX KSCP 24.0040X	IEC 60079-0: 2017 Ed. 6 IEC 60079-11: 2011 Ed. 6
	Ex ia IIC T4 Ga	
ATEX	KSCP 24ATEX0022X	EN IEC 60079-0:2018 EN 60079-11:2012
	CE0080  II1G Ex ia IIC T4 Ga -20°C ≤ Ta ≤ +50°C	
KCs	KGS 24-xxxxx-xxxxX	

8. Trouble Shooting

Issue	Cause	Solution
Device does not Power on	No battery	Charge the battery and use the device
"!" displayed on the screen	Device error	Restart the device or replace the sensor
Cannot measure gas	Calibration needed, Sensor filter contamination	Perform Calibration, Clean/Replace the Sensor filter
Alarm sounds without reason	Calibration required Device Error	Perform Calibration Replace Sensor
Calibration Failure	Configuration Error Device Error	Replace Sensor Perform Calibration
Battery Not Charging	Charger Error Device Error	Replace Battery Check charger Connection
Charging Continuously, Unable to reach 100%		Turn off the device and continue charging

LIMITED WARRANTY

SENKO warrants this product to be free of defects in workmanship and materials-under normal use and service for two years from the date of purchase from the manufacturer or from the product's authorized reseller.

The manufacturer is not liable (under this warranty) if its testing and examination disclose that the alleged defect in the product does not exist or was caused by the purchaser's (or any third party's) misuse, neglect, or improper installation, testing, or calibrations. Any unauthorized attempt to repair or modify the product, or any other cause of damage beyond the range of the intended use, including damage by fire, lightning, water damage or other hazard, voids liability of the manufacturer.

If a product should fail to perform up to manufacturer specifications during the applicable warranty period, please contact the product's authorized reseller or SENKO Service Centre at +44 1918 299930 to repair/return information.



T: +44 1918 299930 Latest@Senkoeurope.com www.Senkoeu.com
Senko Europe, Jarrow Business Centre,
Rolling Mill Rd, Jarrow,
NE32 3DT